

Electric motor or gas engine must be purchased separately.

Sleeved Direct-Drive Plunger Pumps

Electric Models 4SF32ELS
4SF40ELS, 4SF45ELS
4SF50ELS

Gas Models 4SF30GS1
4SF35GS1, 4SF40GS1
4SF45GS1, 4SF50GS1

PUMP FEATURES

- Triplex design provides continuous liquid flow forward through the pump, reduces cavitation risk and increases pump life.
- Unique spring loaded inlet valves and the flow through ceramic plungers allow excellent suction capabilities.
- Compact, hollow shafted pump for direct mounting to either gas or electric motor, eliminates the need for pulleys, belts, gearboxes.
- Regulating Unloader mounts directly on each pump to assure system pressure control and pump protection.
- Convenient multiple porting provides installation flexibility.

COMMON PUMP SPECIFICATIONS

Inlet Pressure Range (Electric).....	-2 to 75 PSI	(-0.14 to 5.25 BAR)
Inlet Pressure Range (Gas).....	Flooded to 75 PSI	(Flooded to 5.25 BAR)
Bore.....	0.787"	(20 mm)
Maximum Liquid Temperature.....	160°F	(71°C)
Above 130°F call CAT PUMPS for inlet conditions and elastomer recommendations.		
Crankcase Capacity.....	23.66 oz.	(0.70 L)
Inlet Port (1).....	1/2" NPTF	(1/2" NPTF)
By-Pass Port (1).....	3/8" NPTF	(3/8" NPTF)
Discharge Ports 2).....	3/8" NPTF	(3/8" NPTF)
Auxiliary Port (1).....	1/4" NPTF	(1/4" NPTF)
Weight (Pump Only).....	24.31 lbs.	(11.0 kg)
Dimensions (Pump Only).....	8.27 x 11.06 x 12.28"	(210x281x312 mm)

⚠ WARNING

All systems require both a primary pressure regulating device (i.e., regulator, unloader) and a secondary pressure safety relief device (i.e., pop-off valve, safety valve). Failure to install such relief devices could result in personal injury or damage to the pump or to system components. CAT PUMPS does not assume any liability or responsibility for the operation of a customer's high pressure system.

SPECIFICATIONS

	U.S. Measure	Metric Measure	U.S. Measure	Metric Measure
Models - Electric	4SF32ELS		4SF40ELS	
Flow	3.2 GPM	(12.1 L/M)	4.0 GPM	(15 L/M)
Max. Discharge Pressure	3500 PSI	(245 BAR)	3500 PSI	(245 BAR)
Max. RPM.....	1725 RPM	(1725 RPM)	1725 RPM	(1725 RPM)
Stroke	0.311"	(7.9 mm)	0.382"	(9.7 mm)
Model - Electric	4SF45ELS		4SF50ELS	
Flow	4.5 GPM	(17 L/M)	5.0 GPM	(19 L/M)
Max. Discharge Pressure	3000 PSI	(210 BAR)	3000 PSI	(210 BAR)
Max. RPM.....	1725 RPM	(1725 RPM)	1725 RPM	(1725 RPM)
Stroke	0.437"	(11.1 mm)	0.453"	(11.5 mm)
Models - Gas	4SF30GS1		4SF35GS1	
Flow	3.0 GPM	(11.4 L/M)	3.5 GPM	(13.2 L/M)
Max. Discharge Pressure	3500 PSI	(245 BAR)	3500 PSI	(245 BAR)
Max. RPM.....	3200 RPM	(3200 RPM)	3200 RPM	(3200 RPM)
Stroke	0.173"	(4.4 mm)	0.197"	(5.0 mm)
Models - Gas	4SF40GS1		4SF45GS1,GS118	
Flow	4.0 GPM	(15 L/M)	4.5 GPM	(17 L/M)
Max. Discharge Pressure	3500 PSI	(245 BAR)	3000 PSI	(210 BAR)
Max. RPM.....	3200 RPM	(3200 RPM)	3200 RPM	(3200 RPM)
Stroke	0.224"	(5.7 mm)	0.256"	(6.5 mm)
Models - Gas	4SF50GS1			
Flow	5.0 GPM (19 L/M)			
Max. Discharge Pressure	3000 PSI (210 BAR)			
Max. RPM.....	3200 RPM (3200 RPM)			
Stroke	0.276" (7.0 mm)			

ELS = **Electric 1-1/8"** hollow shaft with bolt mount
 GS1 = **Gas 1"** hollow shaft with bolt and adapter mount
 GS118 = **Gas 1-1/8"** hollow shaft with bolt and adapter mount
 S = Sleeved piston rod

• For **MAXIMUM SUCTION** capability, Regulating Unloader should be remounted on discharge manifold, OPPOSITE from inlet port.

Refer to pump Service Manual for repair procedures and additional technical information.

"Customer confidence is our greatest asset"

EXPLODED VIEW

June 2004

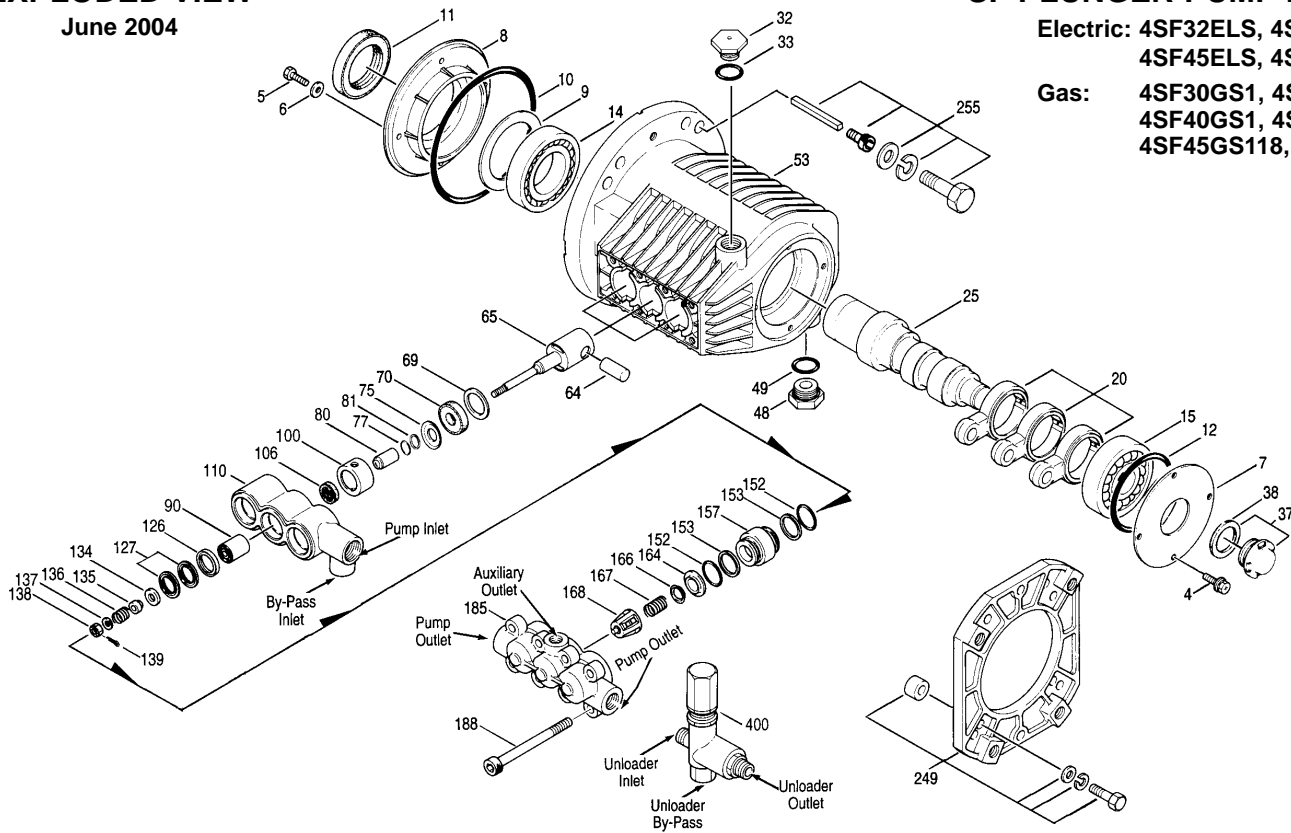

SF PLUNGER PUMP MODELS

Electric: 4SF32ELS, 4SF40ELS
4SF45ELS, 4SF50ELS

Gas: 4SF30GS1, 4SF35GS1
4SF40GS1, 4SF45GS1
4SF45GS118, 4SF50GS1

PARTS LIST

ITEM	PN	MATL	DESCRIPTION	MODEL USED	QTY	ITEM	PN	MATL	DESCRIPTION	MODEL USED	QTY
4	92519	STZP	Screw, Sems HHC (M6x16)	All Models	4	139	14158	S	Cotterpin (M1.6x10)	All Models	3
5	92520	STZP	Screw, Sems HHC (M6x20)	All Models	4	152	43781	NBR	O-Ring, Adapter - 75D	All Models	6
6	150810	NBR	Washer, Seal (M6)	All Models	4	153	21986	PTFE	Back-up-Ring, Adapter	All Models	6
7	45707	AL	Cover, Bearing (Outer)	All Models	1	157	45192	BB	Adapter	All Models	3
8	45172	AL	Case, Bearing (Inner)	All Models	1	164	45194	S	Seat	All Models	3
9	45173	STZP	Washer, Bearing	All Models	1	166	43721	S	Valve	All Models	3
10	89811	NBR	O-Ring, Bearing Cover	All Models	1	167	43751	S	Spring	All Models	3
11	141852	NBR	Seal, Oil	All Models	1	168	44564	PVDF	Retainer, Spring	All Models	3
12	14037	NBR	O-Ring, Bearing Cover	All Models	1	185	45193	BB	Manifold, Discharge	All Models	1
14	45174	STL	Bearing, Ball (Inner)	All Models	1	188	87860	STZP	Screw, HSH (M8x100)	All Models	8
15	45175	STL	Bearing, Ball (Outer)	All Models	1	249	30972		Assy, Adapter Mount, Gas (Long Shaft Eng.)	30GS1, 35GS1, 40GS1, 45GS1, 50GS1	1
20	45572	HS	Rod, Connecting	All Models	3	45215	AL		Flange		1
25	46321	FCM	Crankshaft (4.4mm)	30GS1	1	45216	S		Spacer		4
	46200	FCM	Crankshaft (7.9mm)	32ELS	1	12490	STZP		Washer, Flat (M10)		4
	46161	FCM	Crankshaft (5.0mm)	35GS1	1	12503	STZP		Lockwasher (M10)		4
	45575	FCM	Crankshaft (5.7mm)	40GS1	1	44968	STZP		Screw, HH (3/8-16x1-1/2")		4
	45574	FCM	Crankshaft (6.5mm)	45GS1	1	255	30518	STZP	Assy, Bolt Mount, Gas	30GS1, 40GS1, 45GS1, 50GS1	1
	45573	FCM	Crankshaft (6.5mm)	45GS118	1	19891	STZP		Washer (M12)		4
	45571	FCM	Crankshaft (9.7mm)	40ELS	1	12508	STZP		Lockwasher (M12)		4
	45570	FCM	Crankshaft (11.1mm)	45ELS	1	45208	STZP		Screw, HH (1/2-13x45)	Included with Pump	4
	45741	FCM	Crankshaft (11.5mm)	50ELS	1	44455	STL		Key (1/4"x1/4"x2-5/32") HD		1
	46315	FCM	Crankshaft (7.0mm)	50GS1	1	87788	STZP		Screw, Set HSH (M5x8)		1
32	45690	RTP	Cap, Oil Filler	All Models	1	6106	—		Lubricant, Antiseize		1
33	14179	NBR	O-Ring, Oil Filler Cap - 70D	All Models	1	255	30511	STZP	Assy, Bolt Mount, 2-set Screw	35GS1	1
37	92241	NBR	Gauge, Bubble Oil w/Gasket - 80D	All Models	1	255	30513	STZP	Assy, Bolt Mount, Electric	32ELS, 40ELS, 45ELS, 50ELS	1
38	44428	NBR	Gasket, Flat Flex - 80D	All Models	1	19891	STZP		Washer (M12)		4
48	44842	NY	Plug, Drain (1/2" NPT)	All Models	1	12508	STZP		Lockwasher (M12)		4
49	14179	NBR	O-Ring, Drain Plug - 70D	All Models	1	45208	STZP		Screw, HH (1/2-13x45)	Included with Pump	4
53	45168	AL	Crankcase	All Models except 35GS1	1	46076	STL		Key (1/4"x1/4"x2-1/2") HD		1
	48285	AL	Crankcase (2-set Screw)	4SF35GS1	1	87788	STZP		Screw, Set, HSH (M5x8)		1
64	45179	CM	Pin, Crosshead	All Models	3	6106	—		Lubricant, AntiSeize		1
65	46644	SHS	Rod, Sleeve, Plunger	All Models	3	255	30974		★ ★ Assy, Bolt Mount (Short Shaft Eng.)	30GS1, 35GS1, 40GS1, 45GS1, 50GS1	1
69	26952	STZP	Washer, Seal	All Models	3	45220	AL		Spacer		4
70	27339	NBR	Seal, Oil	All Models	3	34100	STZP		Screw, HH (3/8-16x1-3/8")		4
75	43568	S	Slinger, Barrier	All Models	3	12503	STZP		Lockwasher (M10)		4
77	25392	NBR	O-Ring, Sleeve	All Models	3	30980	STZP		Washer (3/8")		4
80	46646	SS	Sleeve	All Models	3	44455	STL		Key (1/4"x1/4"x2-1/2")		1
81	29003	PTFE	Back-up-Ring, Sleeve	All Models	3	87788	STZP		Screw, Set, HSH (M5x8)		1
90	45848	CC	Plunger (M20x24)	All Models	3	6106	—		Lubricant, Antiseize		1
100	45183	PVDF	Retainer, Seal	All Models	3	285	80228	STL	Screw (M8-1.25x80), Engine Removal	All Models	2
106	45188	NBR	Seal, LPS w/S-Spg	All Models	3	300	34054	NBR	Kit, Seal (Incls: 106,127,139,152)	All Models	1
110	45187	BB	Manifold, Inlet	All Models	1	305	34063	NBR	Kit, Sleeve & Seal (Incls: 75,77,80,81,106,127,139,152)	All Models	1
126	45190	BB	Adapter, Female	All Models	3	310	34055	NBR	Kit, Valve (Incls: 152,153,164,166,167,168)	All Models	1
127	45191	SNG	V-Packing	All Models	6	311	34770	NBR	Kit, Inlet Valve (Incls: 134-137, 139, 152)	All Models	1
134	45845	S	Valve, Inlet	All Models	3	352	44050	STZP	Tool, Oil Gauge Removal	All Models	1
135	44871	S	Spacer, Inlet	All Models	3	400	7600S	BB	Unloader, Regulating	All Models	1
136	45186	S	Spring, Inlet Valve	All Models	3	—	6107		Oil, Bottle (21 oz.) ISO 68 Multi-viscosity Hydraulic	All Models	1
137	88575	S	Washer, Conical (M6)	All Models	3				(Fill to specified crankcase capacity prior to start-up)		
138	27000	S	Nut, Slotted (M6)	All Models	3						

Italics are optional items. See Tech Bulletins 002, 036, 043, 055, 057, 064, 065, 070, 074, 075 and 083 for additional information.

MATERIAL CODES (Not Part of Part Number): AL=Aluminum BB=Brass CC=Ceramic CM=Chrome-moly FCM=Forged Chrome-moly HS=High Strength NBR=Medium Nitrile (Buna-N) NY=Nylon

PTFE=Pure Polytetrafluoroethylene PVDF=Polyvinylidene Fluoride RTP=Reinforced Composite S=304SS SHS=304SS/High Strength SNG=Special Blend (Buna) SS=316SS STL=Steel STZP=Steel/ZincPlated

★ ★ Substitute special BS Bolt Kit when Briggs-Stratton engine is used. Installation of a shaft retaining bolt, flat washer and lockwasher is also recommended when using the Briggs-Stratton engine to secure key.

UNLOADER SPECIFICATIONS

Model 7600S	U.S. Measure	Metric Measure
GPM	2.0-5.0 GPM	(7.6-19 L/M)
PSI (7600S).....	700-3500 PSI	(50-245 BAR)
Inlet Port - Rear.....	3/8" NPTM	(3/8" NPTM)
Discharge Port - Front.....	3/8" NPTM	(3/8" NPTM)
By-Pass Port - Bottom.....	3/8" NPTF	(3/8" NPTF)
Weight	21.4 oz.	(0.65 kg)
Dimensions.....	3.25 x 1.0 x 4.81"	(76 x 25 x 108mm)

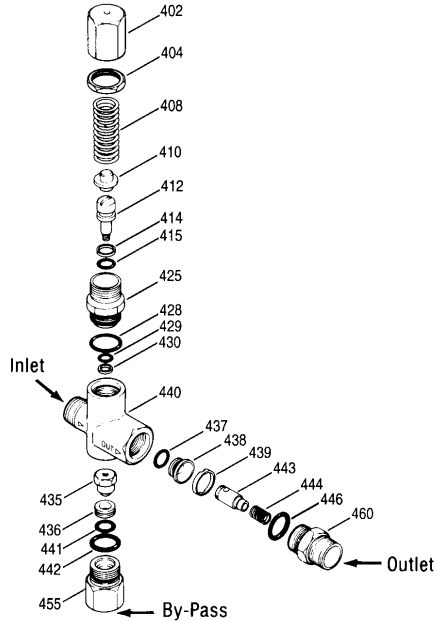

ITEM	PN	MATL	DESCRIPTION	QTY.
402	45197	BB	Cap, Hex Adjusting	1
404	45201	BB	Nut, Lock (M25x1)	1
408	45198	ZP	Spring, Pressure	1
410	45199	BB	Retainer, Spring	1
412	45694	S	Stem, Piston (M5)	1
414	20184	PTFE	Back-up-Ring, Piston Stem	1
415	14190	NBR	O-Ring, Piston Stem - 70D	1
425	45200	BB	Retainer, Piston	1
428	26133	NBR	O-Ring, Piston Guide - 80D	1
429	14759	NBR	O-Ring, Body	1
430	107675	PTFE	Back-up-Ring, Body	1
435	45716	S	Valve and Ball Assembly (M5)	1
436	107680	S	Seat	1
437	26127	NBR	O-Ring, Seat	1
438	45206	S	Seat, C-Valve	1
439	45205	BB	Collar	1
440	—	BB	Body	1
441	13963	NBR	O-Ring, Seat - 70D	1
442	26133	NBR	O-Ring, Adapter - 80D	1
443	35203	BB	Valve, Check w/O-Ring	1
444	45924	S	Spring - 85G	1
446	26133	NBR	O-Ring, Discharge Fitting - 80D	1
455	45695	BB	Fitting, By-Pass (3/8" NPT)	1
460	107681	BB	Fitting, Discharge (3/8" NPT)	1
465	7091	BB	By-Pass Hose (1/2x24") 160°F	1
466	7091.41	BB	By-Pass Hose w/Thermo Valve	1
468	32098	NBR	Kit, O-Ring (Incls: 414, 415, 428, 429, 430, 441, 442, 437, 446)	1
485	7141	BB	Valve, Thermo 145°F	1

Italics are optional items.
 MATERIAL CODES (Not Part of Part Number): BB=Brass NBR=Medium Nitrile (Buna-N)
 PTFE=Pure Polytetrafluoroethylene S=304SS STZP=Steel/Zinc Plated ZP=Zinc Plated

OPERATION

A Regulating Unloader comes with each SF pump to provide system pressure regulation and pump protection.

For **MAXIMUM SUCTION** capability, Regulating Unloader should be remounted on discharge manifold, **OPPOSITE** from pump inlet port.

By-pass for the regulating unloader may drain to the ground, drain to a reservoir or connect to the special 3/8" by-pass port on the underside of the inlet manifold. A 3/8" flexible hose is recommended.

BY-PASS HOSE ASSEMBLY is designed for cold water or ambient temperature operation. **DO NOT EXCEED 6 MINUTES in BY-PASS** operation. Excessive temperatures will cause premature wear or damage to the pump and **VOID THE WARRANTY**.

Standard units may return the by-pass back to the inlet of the pump by installing a *Thermo Valve* in the by-pass line using 7091.41.

If unit is **INFREQUENTLY USED OR PERIODICALLY STORED**, seals may become dry. **UNDER SUCTION FEED**, system must be **PURGED BEFORE**

CHEMICAL INJECTOR SPECIFICATIONS

Model	Standard 7194	Optional 7193
Flow	4-5 GPM	3-4 GPM
Nozzle Orifice	2.3mm	2.1mm
Hose Barb	1/4"	1/4"
Inlet Port	M18 x 1.0	M18 x 1.0
Discharge Port.....	3/8" NPTM	3/8" NPTM
Weight	6.3 oz.	6.3 oz.
Dimensions.....	2 x 1 x 3"	2 x 1 x 3"

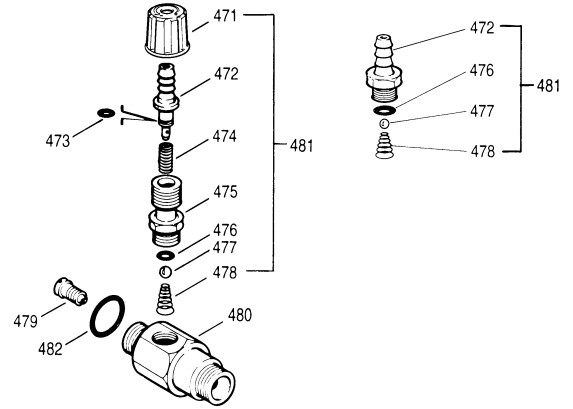

ITEM	PN	MATL	DESCRIPTION	MODEL USED	QTY.
471	33949	NY	Handle, Adjustment	All Models	1
472	32941	BB	Barb, Adjustable	All Models	1
	33505	BB	Barb, Fixed	All Models	1
473	—	NBR	O-Ring, Hose Barb	All Models	1
474	33500	S	Spring	All Models	1
475	33946	BB	Retainer, Ball Seat	All Models	1
476	33504	FPM	O-Ring, Retainer	All Models	1
477	34620	SS	Ball	All Models	1
478	33501	SS	Spring, Tapered	All Models	1
479	32374	S	Orifice, Injector (2.3 mm) Standard	7194	1
	32373	S	Orifice, Injector (2.1mm)	7193	1
480	—	BB	Body	All Models	1
481	33481	BBNY	Barb Assembly, Adjustable (Incls: 471, 472, 473, 474, 475, 476, 477, 478)	All Models	1
	33480	BB	Barb Assembly, Fixed (Incls: 472, 476, 477, 478)	All Models	1
482	26133	NBR	O-Ring, Body - 80D	All Models	1

Italics are optional items.
 MATERIAL CODES (Not Part of Part Number): BB=Brass FPM=Fluorocarbon
 NBR=Medium Nitrile (Buna-N) NY=Nylon S=304SS SS=316SS

Desired Pump Flow	Injector Orifice Size	SF Injector Model	Lo-Pressure Nozzle	Max. Chem. Draw	Hi-Press Nozzle
			(Maximum injecting pressure less hose friction loss)	(0 PSI) (Downstream)	"Deduction" (Press. drop across Inj.)
3.5	2.1 mm	7193	300 PSI	50 oz/min	200 PSI
3.5	2.3 mm	7194	185 PSI	56 oz/min	175 PSI
4.0	2.1 mm	7193	375 PSI	54 oz/min	250 PSI
4.0	2.3 mm	7194	225 PSI	50 oz/min	225 PSI
4.5	2.1 mm	7193	485 PSI	54 oz/min	325 PSI
4.5	2.3 mm	7194	260 PSI	50 oz/min	285 PSI
5.0	2.3 mm	7194	300 PSI	50 oz/min	350 PSI

Optimum performance of chemical injector occurs with a **35 ft. high pressure hose** and a minimum 3/8" I.D. The type of hose, extended lengths, reduced I.D. and fittings may create **back pressures** in excess of the low pressure nozzle rating and **prevent the injector** from drawing chemical. **Deduct hose friction loss from above low PSI Nozzle. Contact CAT PUMPS for assistance with other options.** Refer to Hose Friction Loss Chart in the Service Manual for pressure loss with longer hose.

OPERATION (system liquid must flow through the pump without discharge restriction) to assure full system pressure is reached.

An optional, **specialty ported chemical injector** may be mounted directly to the discharge of the unloader. Remove o-ring, check valve and spring from discharge fitting of unloader; insert into injector and thread into unloader discharge port. **Discard o-ring and discharge fitting.** Refer to the performance chart to determine the orifice size best suited to the system flow. **Chemical draw occurs under low pressure.** Select the *Change Over Nozzle* (32149), *Adjustable Nozzle* (32151), or *Vari-Nozzle* (7930-7980) to permit the adjustment from low to high pressure.

For optimum performance when using a chemical injector, use a **single wire braid hose** on the discharge line. Too flexible a hose will prevent the unloader from receiving the full pressure signal to activate the by-pass mode.

For correct nozzle selection, **read system pressure at the pump. DO NOT READ SYSTEM PRESSURE AT THE HIGH PRESSURE GUN.** Incorrect pressure reading may result in: pump operation at excessive pressures, inconsistent chemical draw or possible damage to the pump or unloader.

MOTOR SPECIFICATIONS

Model 8041

Horsepower.....	5.0 H.P.
Frame Size.....	184 TC TEFC
Phase.....	Single
Max. Volts.....	230 V
Amps.....	26.0 AMPS.
RPM.....	1725 RPM
Motor Only Weight....	90.1 lbs.
Shipping Weight.....	97.1 lbs.
Capacitor Start.....	Yes
Service Factor.....	1.0

Model 8043

Horsepower.....	7.5 H.P.
Frame Size.....	215 TCZ TEFC w/184C FACE
Phase.....	Single
Max. Volts.....	208-230 V
Amps.....	34/31 AMPS.
RPM.....	1725 RPM
Motor Only Weight....	133.4 lbs.
Shipping Weight.....	144.5 lbs.
Capacitor Start.....	Yes
Service Factor.....	1.0

Model 8046

Horsepower.....	10.0 H.P.
Frame Size.....	215 TCZ TEFC w/184C FACE
Phase.....	Three
Max. Volts.....	208-230/460 V
Amps.....	28/26/13 AMPS.
RPM.....	1725 RPM
Motor Only Weight....	140.1 lbs.
Shipping Weight.....	151.1 lbs.
Service Factor.....	1.15

Model 8042

Horsepower.....	5.0 H.P.
Frame Size.....	184 TC TEFC
Phase.....	Three
Max. Volts.....	208-230/460 V
Amps.....	15/13.2/6.6 AMPS.
RPM.....	1725 RPM
Motor Only Weight....	84.0 lbs.
Shipping Weight.....	95.0 lbs.
Service Factor.....	1.15

Model 8044

Horsepower.....	7.5 H.P.
Frame Size.....	215 TCZ TEFC W/184C FACE
Phase.....	Three
Max. Volts.....	208-230/460 V
Amps.....	21.5/20/10 AMPS.
RPM.....	1725 RPM
Motor Only Weight....	110.2 lbs.
Shipping Weight.....	121.3 lbs.
Service Factor.....	1.15

Common Motor Specifications

Thermal Overload-Manual Reset.....	No
Cycle.....	60 HZ
Max. Operating Temp.....	104°F
Shaft Diameter.....	1-1/8"
U.L. Reference.....	E-46145
CSA Reference No.....	LR-2262

- ★ ★ Before mounting pump on motor, apply P.N. 6106 Antiseize Lubricant to pump shaft.
- ★ ★ Refer to Tech Bulletin #055 for instructions on removing pump from gas engine or electric motor.

For warranty consideration contact CAT PUMPS for the local Authorized Baldor Service Center or call direct to Baldor 501*646*4711 for assistance. If you are uncertain as to the cause of failure (Pump or Motor), secure Returned Goods Authorization number and return complete assembly PREPAID to CAT PUMPS for evaluation.

HORSEPOWER REQUIREMENTS

MODEL	FLOW		PRESSURE					PUMP RPM
			PSI 1500	PSI 2000	PSI 2500	PSI 3000	PSI 3500	
	U.S. GPM	Metric L/M	BAR 105	BAR 140	BAR 175	BAR 210	BAR 245	
4SF32ELS	3.2	12.1	3.3	4.4	5.5	6.6	7.7	1725
4SF40ELS	4.0	15	4.1	5.5	6.9	8.3	9.5	1725
4SF45ELS	4.5	17	4.6	6.2	7.7	9.3	N/A	1725
4SF50ELS	5.0	19	5.1	6.9	8.6	10.3	N/A	1725

DETERMINING THE REQUIRED H.P.

$$\frac{\text{GPM} \times \text{PSI}}{1460} = \text{Electric Brake H.P. Required}$$

4SF DIMENSIONAL

	A	B	C	D	E	F	G	H	I	J	K	L	M
4SF30GS1, 4SF35GS1, 4SF40GS1, 4SF45GS1, 4SF45GS118, 4SF50GS1	7.44(189)	4.92(125)	11.06(281)	11.85(301)	8.27(210)	4.01(102)	12.28(312)	8.31(211)	8.66(220)	9.44(210)	3.43(87)	6.18(157)	2.68(68)
4SF32ELS, 4SF40ELS, 4SF45ELS, 4SF50ELS	7.44(189)	4.92(125)	11.06(281)	—	8.27(210)	4.01(102)	12.28(312)	8.31(211)	8.66(220)	—	3.43(87)	6.18(157)	2.68(68)

	N	O	P	P2	Q	R	S	T	U	V	W
8041	13.94(354)	12.81(325)	11.56(294)	—	22.60(574)	7.5(190)	.41 DIA(10)	3.5(89)	5.5(140)	5.88(149)	—
8042	13.94(354)	12.81(325)	—	9.00(229)	22.60(574)	7.5(190)	.41 DIA(10)	3.5(89)	5.5(140)	5.88(149)	—
8043	16.75(425)	13.40(340)	10.06(269)	—	25.41(645)	8.5(216)	.41 DIA(10)	4.25(108)	5.5(140)	—	8.75(222)
8044	15.56(395)	13.40(340)	—	12.44(316)	24.22(615)	8.5(216)	.41 DIA(10)	4.25(108)	5.5(140)	—	8.75(222)
8046	15.56(395)	13.40(340)	—	12.44(316)	24.22(615)	8.5(216)	.41 DIA(10)	4.25(108)	5.5(140)	—	8.75(222)

Products described hereon are covered by one or more of the following U.S. patents 3558244, 3652188, 3809508, 3920356, 3930756 and 5035580

World Headquarters
CAT PUMPS
 1681 - 94th Lane N.E. Minneapolis, MN 55449-4324
 Phone (763) 780-5440 — FAX (763) 780-2958
 e-mail: techsupport@catpumps.com
 www.catpumps.com

International Inquiries
 FAX (763) 785-4329
 e-mail: intlsales@catpumps.com



CAT PUMPS (U.K.) LTD.
 1 Fleet Business Park, Sandy Lane, Church Crookham, Fleet
 Hampshire GU52 8BF, England
 Phone Fleet 44 1252-622031 — Fax 44 1252-626655
 e-mail: sales@catpumps.co.uk

N.V. CAT PUMPS INTERNATIONAL S.A.
 Heiveldekens 6A, 2550 Kontich, Belgium
 Phone 32-3-450.7150 — Fax 32-3-450.7151
 e-mail: cpi@catpumps.be www.catpumps.be

CAT PUMPS DEUTSCHLAND GmbH
 Buchwiese 2, D-65510 Idstein, Germany
 Phone 49 6126-9303 0 — Fax 49 6126-9303 33
 e-mail: catpumps@t-online.de www.catpumps.de